

# Sheep

This Sheep was created to commemorate The Year of the Sheep 2003. Start with a 5 x 2 rectangle of paper - white copier paper is ideal. If using A4 copier paper, a rectangle 297mm x 118.8mm can be used.

(1) Make valley creases as shown. Valley fold right hand corners only. Turn over.

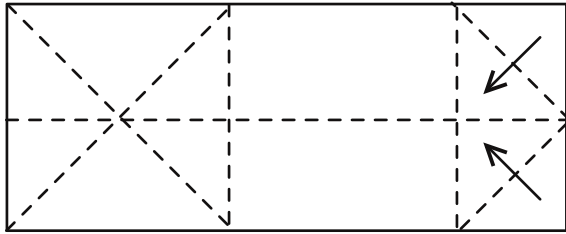

(2a) Valley fold in right hand point. Follow extra diagrams.

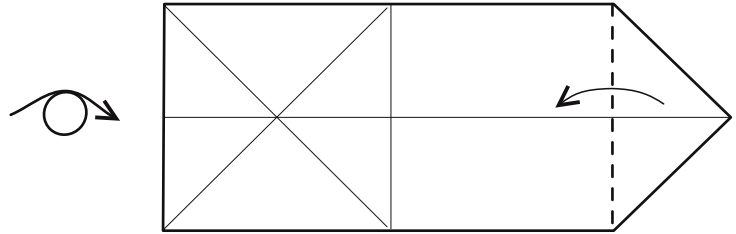

(3) Box-pleat left square, and collapse. At the same time mountain fold whole model in half. Try not to crease areas A and B while doing this.

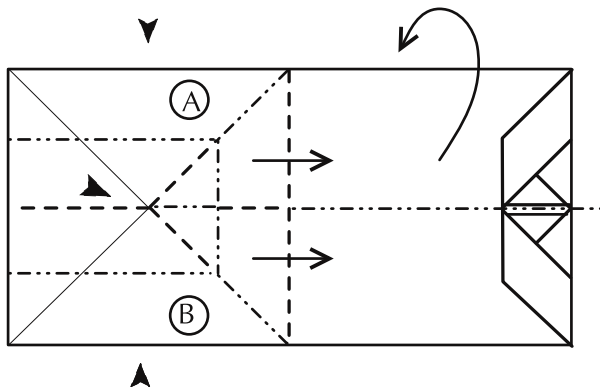

(2b) Sink point.

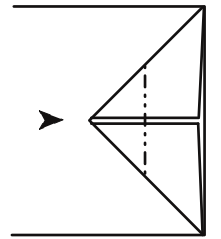

(2c) Fold corners inside.

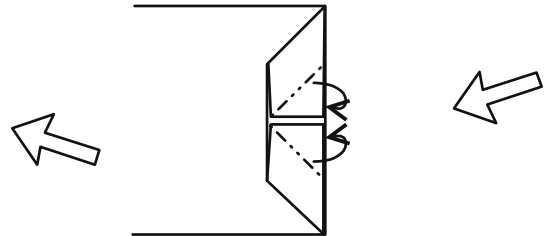

(4) Reverse top portion. This is a 3D reverse - layers must be kept separate in a W shape.

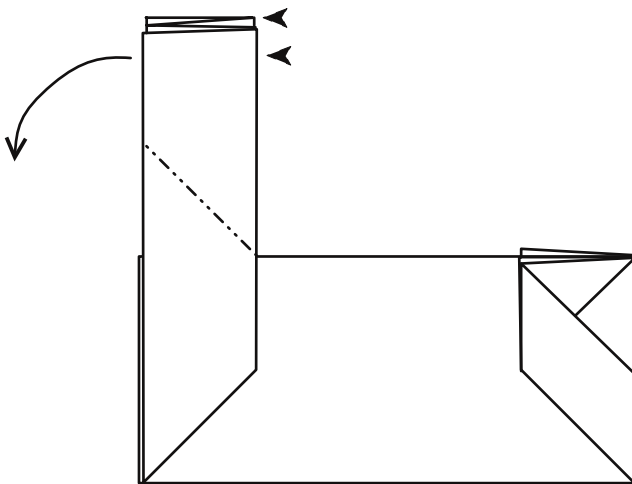

(5) Sink corners and valley each corner to the right. Rotate model 45° anti-clockwise.

