

# ORIGAMI BLACKBELT

This is a variation of the Traditional Kimono design. Start with a 5 x 1 rectangle of paper, black on one side, white on the other. Start with the white side up.

(1) Make waterbomb base on top square then unfold.

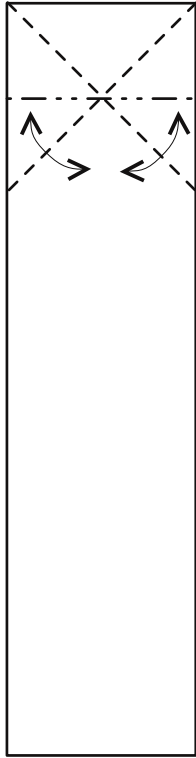

(2) Pre-crease box-pleats

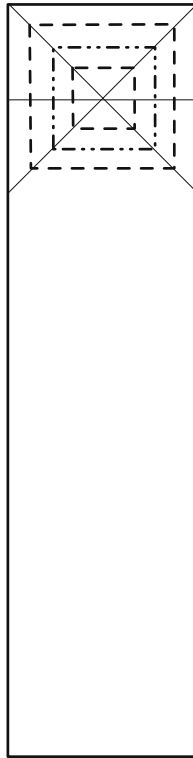

(3) Then collapse pleats

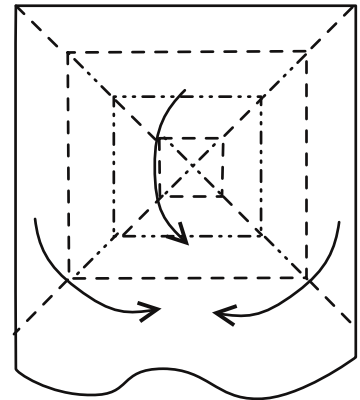

(4) Fold behind bottom edge 1/6 of width of paper. Rotate paper 180 degrees, top to bottom.

(5) Fold in top corners to middle

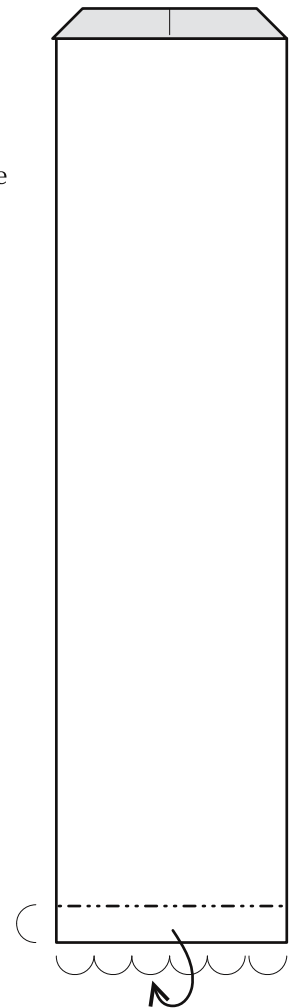
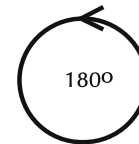
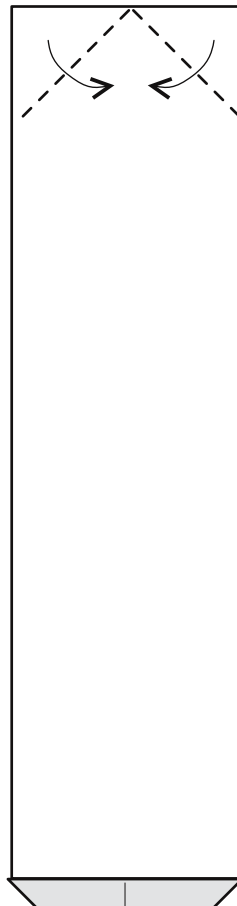

(6) Pleat paper downwards

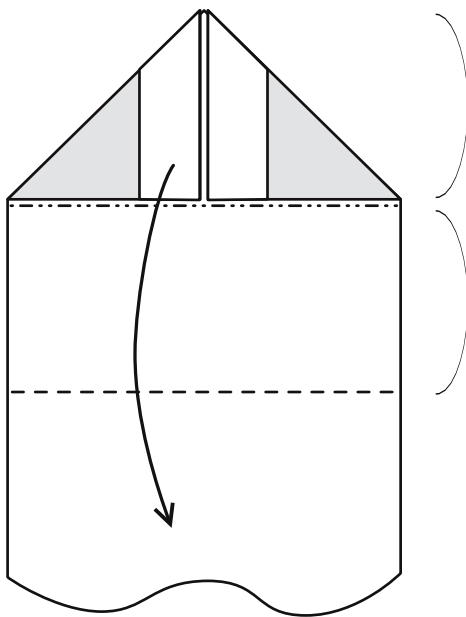

# ORIGAMI BLACKBELT-2

(7) Fold in edges and squash corners.

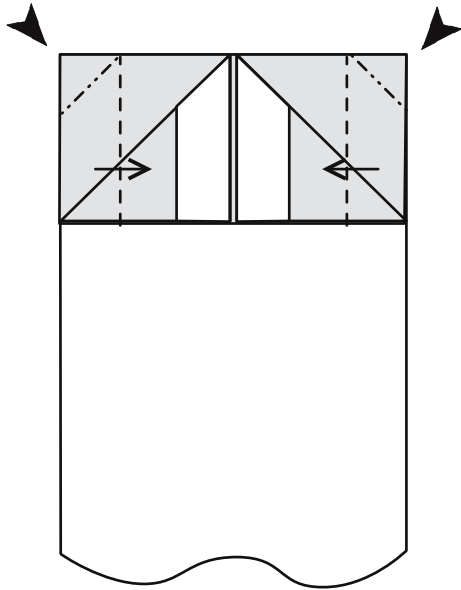

(8) Mountain fold over top edge. Pleat an amount equal to half the width of the paper.

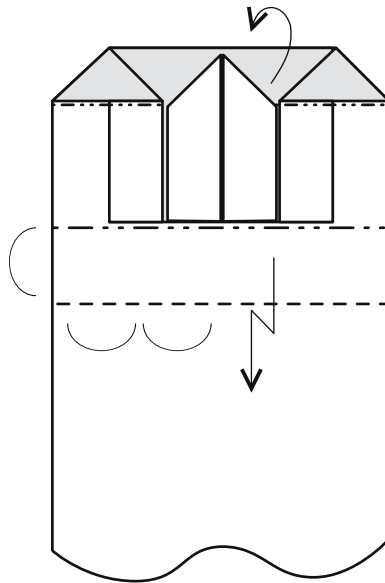

(9) Mountain ends of belt downwards. Fold over side edges, squashing top corners.

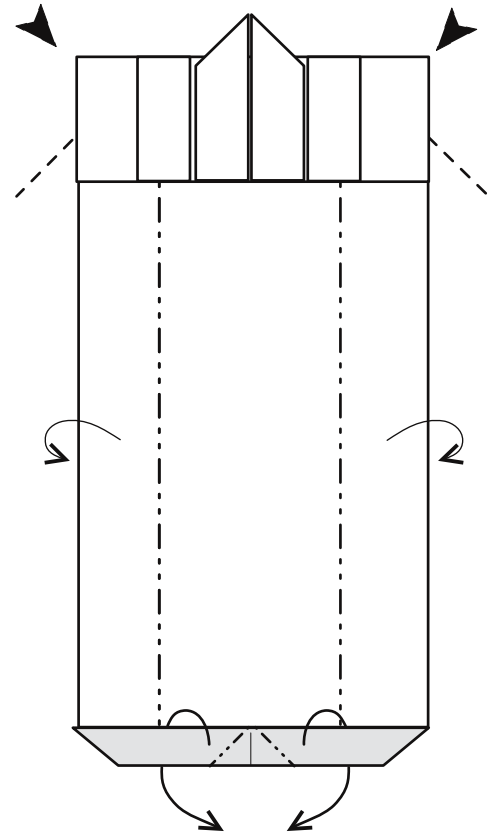

(10) Pleat bottom portion and tuck pleat into pocket to lock model

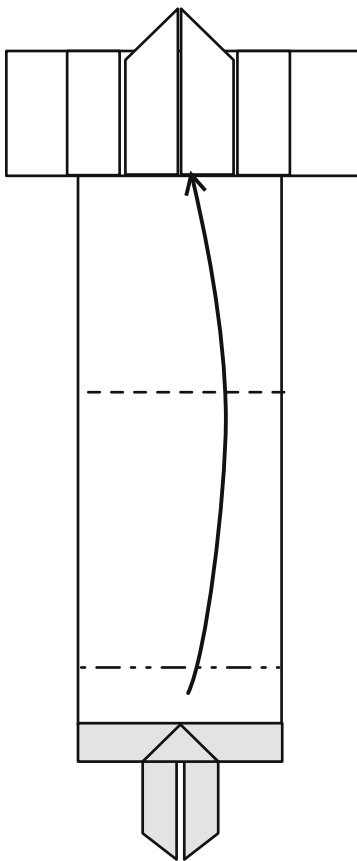

(11) Completed Origami Blackbelt

