

# Jumping Kangaroo - 2

(8) Make crimp to form front legs

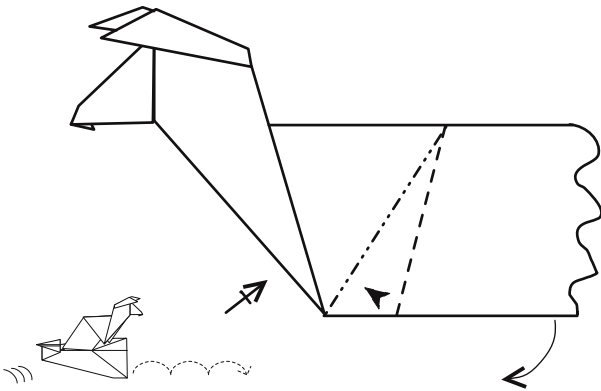

(9) Open out long bottom point to form base of model.

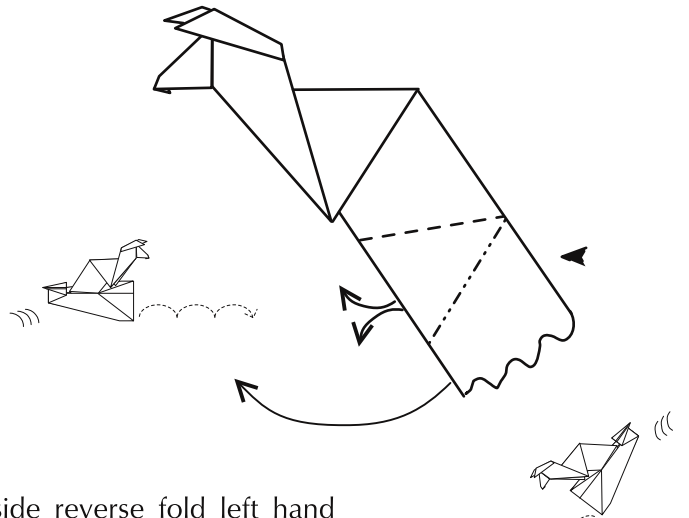

(11) This is the result.  
Tuck corners inside.  
This forms hind legs  
and locks the folds.

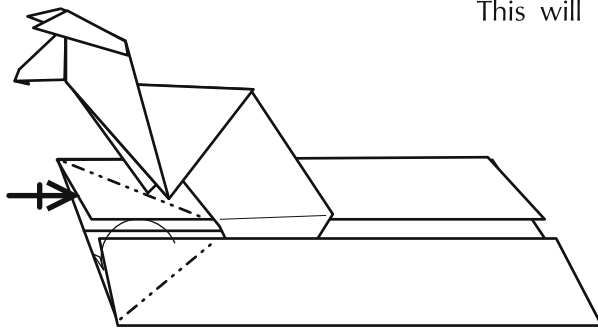

(10) Outside reverse fold left hand  
point over to right. Note - you will  
need to open up some of the  
previous folds to do this.  
This will make kangaroo's tail.

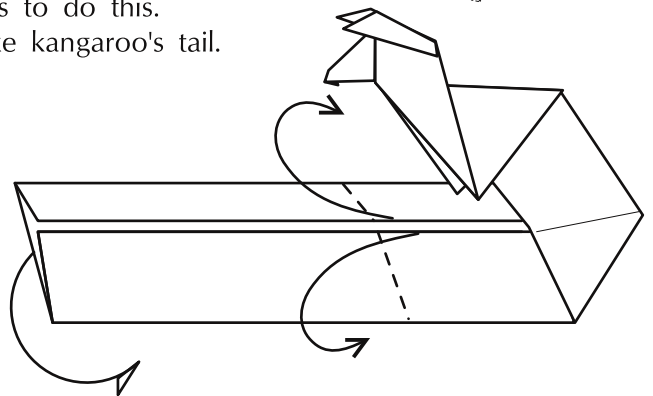

(12) This is view from below.  
Valley fold in corners to centre.

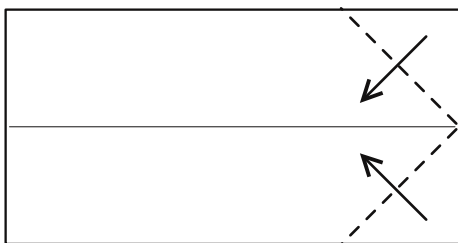

(13) Valley top & bottom edges  
at 30 degree angle so that they overlap.  
These fold lines may or may not go  
to the left corners.

